

SCHOTTKY BARRIER RECTIFIER

VOLTAGE RANGE: 30 --- 200 V
CURRENT:40.0A

FEATURES

- ◇ Metal-semiconductor junction with guard ring
- ◇ Epitaxial construction
- ◇ Low forward voltage drop,low switching losses
- ◇ High surge capability
- ◇ For use in low voltage,high frequency inverters free wheeling,and polarity protection applications
- ◇ The plastic material carries U/L recognition 94V-0

MECHANICAL DATA

- ◇ Case:JEDEC ITO-220AB ,molded plastic
- ◇ Terminals: Axial lead ,solderable per MIL- STD-750,Method 2026
- ◇ Polarity: As marked
- ◇ Weight: 0.08ounces,2.24 grams
- ◇ Mounting position: Any

ITO - 220AB

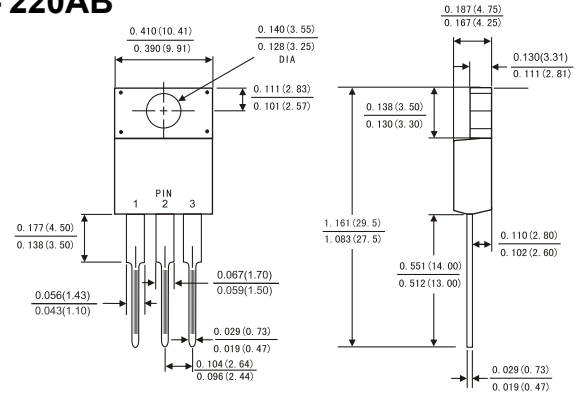

MAXIMUM RATINGS AND ELECTRICAL CHARACTERISTICS

Ratings at 25°C ambient temperature unless otherwise specified.

Single phase,half wave,60 Hz,resistive or inductive load. For capacitive load,derate by 20%.

	Symbols	SRF 4030CT	SRF 4035CT	SRF 4040CT	SRF 4045CT	SRF 4050CT	SRF 4060CT	SRF 40100CT	SRF 40150CT	SRF 40200CT	Units
Maximum repetitive peak reverse voltage	V _{RRM}	30	35	40	45	50	60	100	150	200	Volts
Maximum RMS voltage	V _{RMS}	21	25	28	32	35	42	70	105	140	Volts
Maximum DC blocking voltage	V _{DC}	30	35	40	45	50	60	100	150	200	Volts
Maximum average forward rectified current(see Fig.1)	Per leg	20.0									Amps
	Total device	40.0									
Peak forward surge current 8.3ms single half sine-wave superimposed on rated load (JEDEC method)	I _{FSM}	300.0									Amps
Maximum instantaneous forward voltage at 40.0 A	V _F	0.60			0.75		0.85	0.95			Volts
Maximum instantaneous reverse current at rated DC blocking voltage(Note 1)	T _c = 25°C	0.2									mA
	T _c = 125°C	30			50						
Typical thermal resistance (Note 2)	R _{θJC}	3.0									°C/W
Operating junction temperature range	T _J	-65 to +150									°C
Storage temperature range	T _{STG}	-65 to +150									°C

- NOTE: 1. Pulse test:300us pulse width,1% duty cycle.
2. Measured at 1.0MHz and applied reverse voltage of 4.0V DC.
3. Thermal resistance junction to ambient

FIG.1-FORWARD CURRENT DERATING CURVE

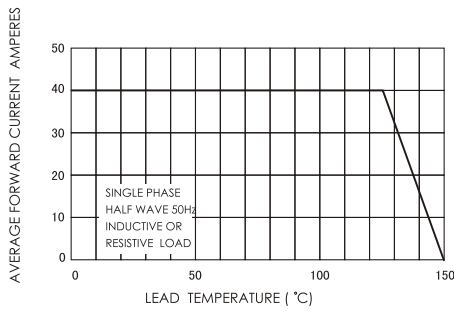

FIG.2-MAXIMUM NON-REPETITIVE PEAK FORWARD SURGE CURRENT

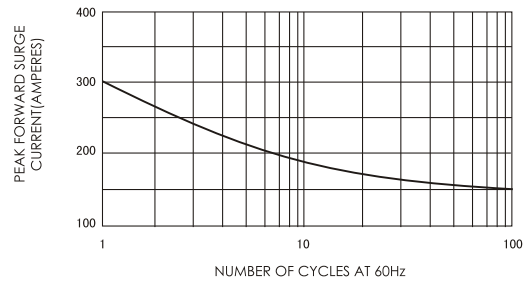

FIG.3-TYPICAL INSTANTANEOUS FORWARD CHARACTERISTICS

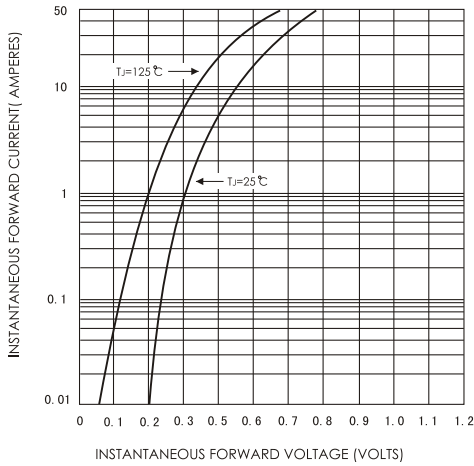

FIG.4-TYPICAL REVERSE CHARACTERISTICS

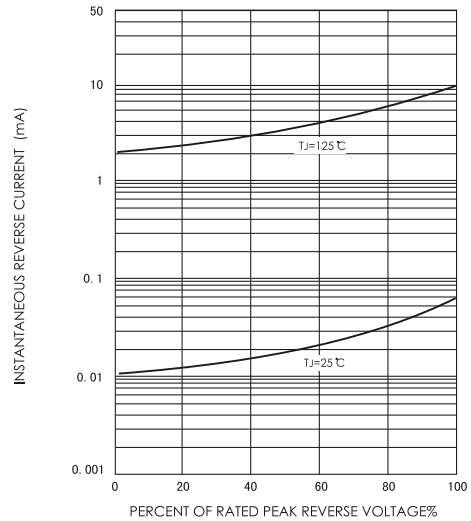

FIG.5-TYPICAL JUNCTION CAPACITANCE

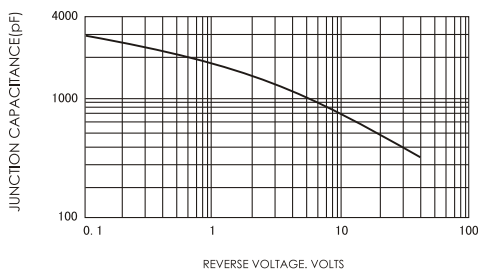

FIG.6-TYPICAL TRANSIENT THERMAL IMPEDANCE

