

SCHOTTKY BARRIER RECTIFIER

VOLTAGE RANGE: 20 --- 200 V
CURRENT: 1.0A

FEATURES

- ◇ Metal-semiconductor junction with guard ring
- ◇ Epitaxial construction
- ◇ Low forward voltage drop, low switching losses
- ◇ High surge capability
- ◇ For use in low voltage, high frequency inverters free wheeling, and polarity protection applications
- ◇ The plastic material carries U/L recognition 94V-0

MECHANICAL DATA

- ◇ Case: JEDEC SMA(DO-214AC), molded plastic
- ◇ Terminals: Axial lead, solderable per MIL-STD-750, Method 2026
- ◇ Polarity: Color band denotes cathode end
- ◇ Weight: 0.002 ounces, 0.064 grams
- ◇ Mounting position: Any

SMA(DO-214AC)

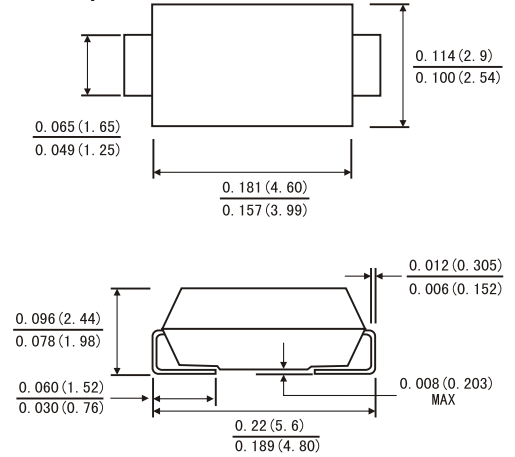

MAXIMUM RATINGS AND ELECTRICAL CHARACTERISTICS

Ratings at 25°C ambient temperature unless otherwise specified.

Single phase, half wave, 60 Hz, resistive or inductive load. For capacitive load, derate by 20%.

	V _{RRM}	SS 12	SS 13	SS 14	SS 15	SS 16	SS 18	SS 110	SS 115	SS 120	Volts	
Maximum repetitive peak reverse voltage	V _{RRM}	20	30	40	50	60	80	100	150	200	Volts	
Maximum RMS voltage	V _{RMS}	14	21	28	35	42	57	71	105	140	Volts	
Maximum DC blocking voltage	V _{DC}	20	30	40	50	60	80	100	150	200	Volts	
Maximum average forward rectified current (See Fig. 1)	I(AV)	1.0									Amp	
Peak forward surge current 8.3ms single half sine-wave superimposed on rated load (JEDEC method)	I _{FSM}	40.0									Amps	
Maximum instantaneous forward voltage at 1.0 A (note 1)	V _F	0.55		0.75			0.85		0.90		0.95	Volts
Maximum instantaneous reverse current at rated DC blocking voltage (Note 1)	I _R	0.2									mA	
		10.0										
Typical thermal resistance (Note 2)	R _{θJA}	88.0									°C/W	
	R _{θJL}	28.0										
Operating junction temperature range	T _J	-65 to +150									°C	
Storage temperature range	T _{STG}	-65 to +150									°C	

- NOTE: 1. Pulse test: 300us pulse width, 1% duty cycle.
2. Measured at 1.0MHz and applied reverse voltage of 4.0V DC.
3. Thermal resistance junction to ambient

FIG.1-FORWARD CURRENT DERATING CURVE

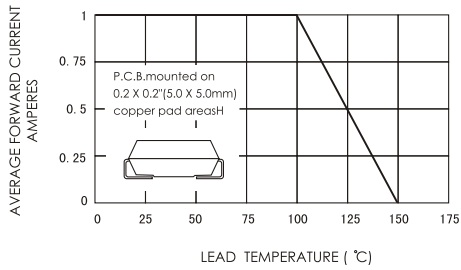

FIG.2-MAXIMUM NON-REPETITIVE PEAK FORWARD SURGE CURRENT

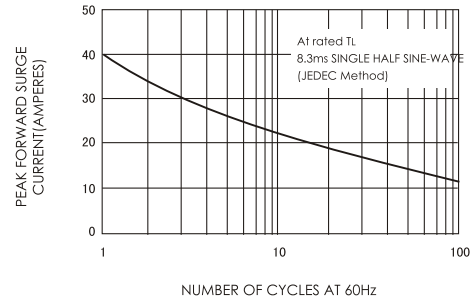

FIG.3-TYPICAL INSTANTANEOUS FORWARD CHARACTERISTICS

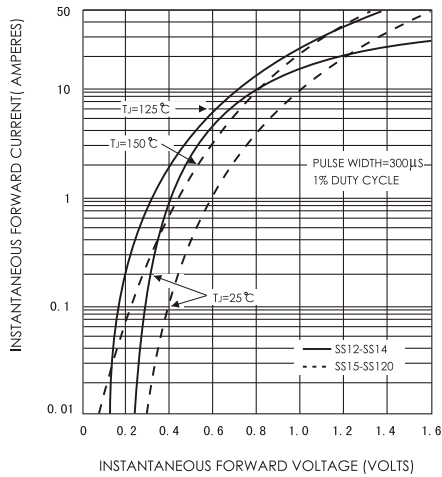

FIG.4-TYPICAL REVERSE CHARACTERISTICS

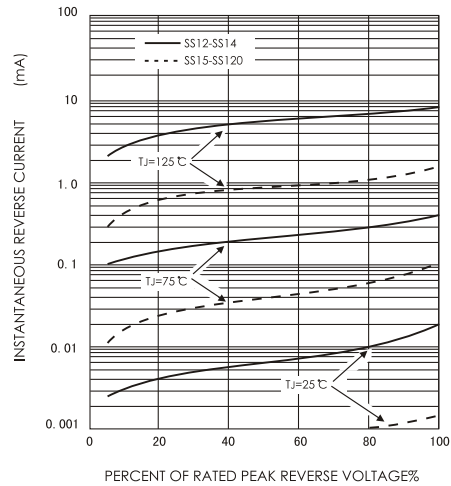

FIG.5-TYPICAL JUNCTION CAPACITANCE

